

# ICE COBOTICS

[www.icecobotics.com](http://www.icecobotics.com)

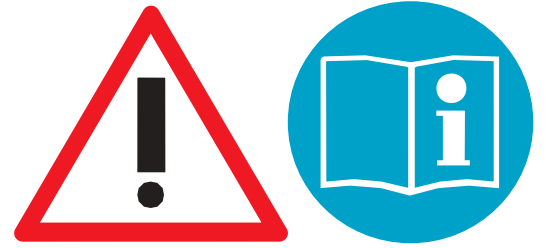

## Operator & Parts Manual

Automatic Scrubber



# i15B

8401902  
REV.02(11-2022)



## READ OPERATOR MANUAL CAREFULLY!

**IMPORTANT:** To ensure full warranty protection, please fill out & return your warranty card.

Please fill out at time of installation for future reference.

Model No. \_\_\_\_\_

Serial No. \_\_\_\_\_

Machine Options \_\_\_\_\_

Sales Rep. \_\_\_\_\_

Sales Rep. Phone No. \_\_\_\_\_

Customer ID Number \_\_\_\_\_

Installation Date \_\_\_\_\_

### HOW TO ORDER PARTS

Only use ICE Company supplied or equivalent parts. Parts and supplies may be ordered from authorized distributor.

1. Identify the machine model.
2. Identify the machine serial number from the data label.
3. Ensure the proper serial number is used from the parts list.
4. Identify the part number and quantity.  
Do not order by page or reference numbers.
5. Provide your name, company name, customer ID number, billing and shipping address, phone number and purchase order number.



#### PROTECT THE ENVIRONMENT

Please dispose of packaging materials, old machine components such as batteries, hazardous fluids, including antifreeze and oil, in an environmentally safe way according to local waste disposal regulations.



Always remember to recycle.

### ICE (International Cleaning Equipment)

4242 58Th St  
Holland, MI, 49423  
Tel: 866-777-1905

Specifications and parts are subject to change without notice.

**TABLE OF CONTENTS**

SAFETY PRECAUTIONS.....	4
MACHINE COMPONENTS.....	5
MACHINE OPERATION .....	6
MACHINE SETUP & INSTALLATION.....	6
WHILE OPERATING MACHINE.....	7
TANK DRAINING.....	8
BATTERY CHARGING.....	8
PREVENTATIVE MAINTENANCE.....	9
BASIC TROUBLESHOOTING.....	10
TECHNICAL SPECIFICATIONS.....	11
PARTS LIST.....	12-25
WEARABLE PARTS.....	26
WIRING DIAGRAM.....	27

## SAFETY PRECAUTIONS

This machine is intended for commercial use. It is designed exclusively to scrub hard floors in an indoor environment and is not constructed for any other use. Only use recommended accessories.

**All operators shall read, understand and exercise the following safety precautions:**

### 1. Do not operate machine:

- Unless you have read and understand the operators manual.
- In flammable or explosive areas.
- If not in proper operating condition.
- In outdoors areas.

### 2. Before starting machine:

- Make sure all safety devices are in place and operate properly.

### 3. When using machine:

- Go slow on inclines and slippery surfaces.
- Follow all safety guidelines.
- Be very careful when using the machine in reverse.
- Reduce speed when turning.
- Report and fix any damage to machine prior to operating it.
- Never allow children to play on or around.
- Do not operate on inclines that exceed 5% (3°).

### 4. Before leaving or servicing machine:

- Stop on level surface.
- Turn off machine.

### 5. When servicing machine:

- Read operators manual thoroughly prior to operating or servicing this machine.
- Use manufacturer supplied or approved replacement parts.
- Secure machine with wheel blocks prior to jacking the machine up.
- Use approved jack or hoist to safely elevate the machine.
- Disconnect batteries prior to working on machine.
- Avoid moving parts. Do not wear loose fitting clothing while servicing machine.

 **WARNING: Fire or Explosion Hazard. Keep sparks and open flames away! Keep battery compartment open when charging.**

 **WARNING: Flammable materials can cause an explosion or fire. Do not use flammable materials in tanks.**

 **WARNING: Flammable materials or reactive metals can cause explosion or fire. Do not pick up.**

**MACHINE COMPONENTS**

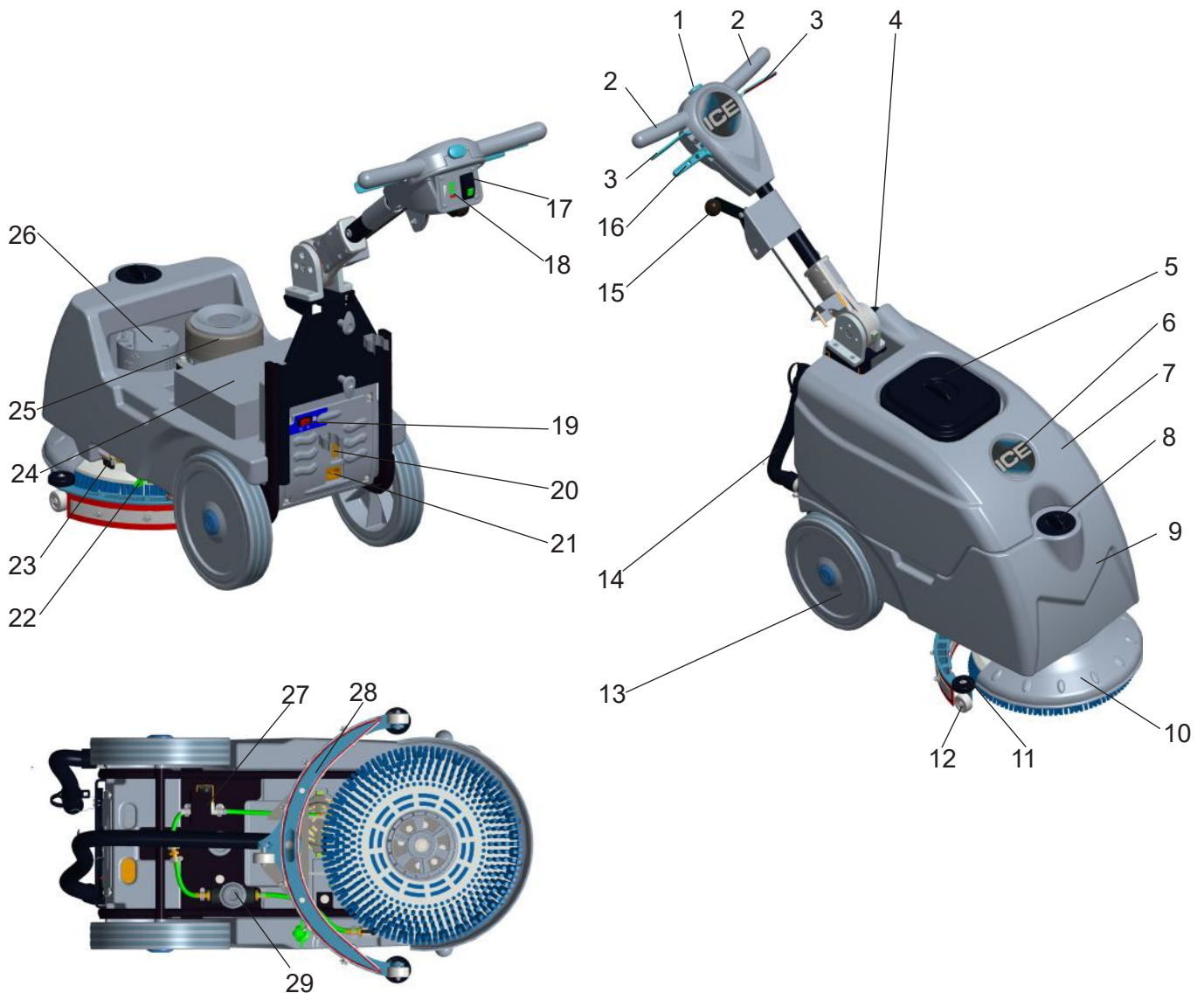

- |                                                |                                         |
|------------------------------------------------|-----------------------------------------|
| 1. Safety Lock-Out Switch                      | 16. Leveling Rod                        |
| 2. Control Handle                              | 17. Main Power ON/OFF Switch            |
| 3. Trigger                                     | 18. Battery Discharge Indicator         |
| 4. Squeegee Vacuum Hose                        | 19. Vacuum Power ON/OFF Switch          |
| 5. Recovery Tank Cover                         | 20. Clear Cover, Battery Charger        |
| 6. ICE Logo                                    | 21. Connector, On-Board Battery Charger |
| 7. Recovery Tank                               | 22. Clean Water Tank Drain Cover        |
| 8. Bucket Fill Port/ Clean-Out Port            | 23. Ball Valve                          |
| 9. Solution Tank                               | 24. Battery                             |
| 10. Scrub head                                 | 25. Vacuum Motor, 24VDC                 |
| 11. Bumper Rollers                             | 26. Brush Motor, 24VDC                  |
| 12. Caster, 1.5Inch, Squeegee Blade Adjustment | 27. Solenoid, 24VDC                     |
| 13. 10 Inch wheels                             | 28. Squeegee Assembly                   |
| 14. Recovery Tank Drain Hose                   | 29. Filter Assembly                     |
| 15. Squeegee Lift Lever                        |                                         |

# OPERATOR MANUAL

## MACHINE OPERATION

**FOR SAFETY: Do not operate machine unless operator manual is read and understood.**

### PRE-OPERATION

1. **IMPORTANT:** To prevent vacuum system from clogging, sweep and dust-mop floor.
2. Make sure battery is charged.
3. Check that the brush and squeegee blades are installed.

### SCRUBBING FLOORS

**FOR SAFETY: Before Operating machine, follow safety guidelines concerning wet floors.**

**⚠ WARNING: Fire or Explosion Hazard, Do Not Use or Pick Up Flammable Materials.**

**⚠ WARNING: Spinning Brush. Keep Hands Away.**

1. Pull the handle adjustment lever and adjust the handle to a comfortable operating height. Release the lever to lock the position.



2. Press the main power switch to the on ( I ) position.



3. Press the vacuum switch to the on ( I ) position.



4. To begin scrubbing, first press the safety switch (1), pull the start triggers (2) and push or pull the machine in either direction.



5. For heavily soiled areas, use the double scrub method. First scrub the soiled area with the vacuum switch turned off then scrub the area a second time with vacuum switch turned on.



## MACHINE SET UP & INSTALLATION

### UNCRATING MACHINE

Be sure and check packing carton for any damage. Immediately report any damage to carrier. Check the contents of package to ensure that the following items are included:

- Machine
- 2-12V Batteries
- Squeegee assembly
- Battery Charger
- Brush
- Pad Driver

### INSTALLING BATTERIES

**The batteries are already in the machine upon delivery; However you will need to connect the cables to the battery posts.**

**⚠ WARNING: Fire or Explosion Hazard. Keep sparks and open flames away! Keep battery compartment open when charging.**

1. Turn off the machine.
2. Lift the Recovery tank (see machine components, p5 item #2) to access the battery compartment.

- Connect battery cables to posts as shown in drawing below.  
**RED to POSITIVE and BLACK to NEGATIVE.**

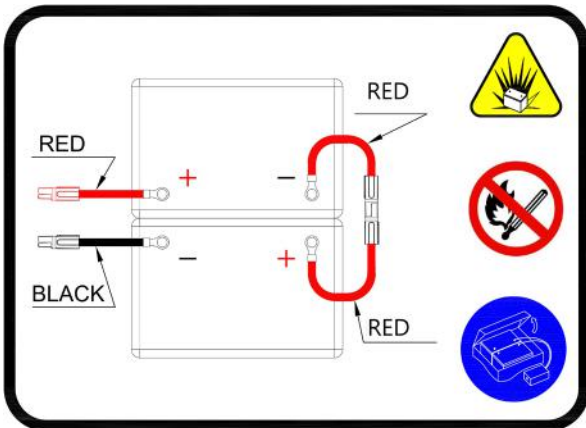

## MACHINE SET UP

### PRE-OPERATION CHECKS

- Sweep or dust mop the surface to be cleaned.
- Check battery meter to make sure batteries are fully charged. (See BATTERY CHARGING)
- Check that squeegee is properly installed.
- Check that brush / pad is properly installed.

### MOUNTING THE SQUEEGEE ASSEMBLY

- Lower the Squeegee lift lever to the downward position.
- Mount the Squeegee assembly (see machine components, p5 item #28) to the squeegee pivot bracket. make sure the knobs are completely seated into the slots before securing knobs.
- Connect the vacuum hose to the squeegee assembly. Loop the hose by using the hose clip provided.
- Check the squeegee blades for proper adjustment.

### FILLING THE SOLUTION TANK

The machine is equipped with a Solution fill-port (see machine components, p5 item #8) at the front of the Solution tank, you can fill the solution tank by using a hose or a bucket.

When using the bucket, stop filling when the level reaches the bottom edge of the fill-port.

**Conventional scrubbing** - Fill solution tank with water (not to exceed 60°C/140°F). Pour a recommended cleaning detergent into the solution tank according to mixing instructions on the container.

**NOTE:** When filling the solution tank with a bucket, make sure that the bucket is clean. Do not use the same bucket for filling and draining the ma-

chine.

**! WARNING:** Do not put any flammable materials into solution tank. This can cause an explosion or a fire. Only use recommended cleaning chemicals. Contact your Simple Clean Scrubbers dealer for recommendations on proper chemicals.

## WHILE OPERATING MACHINE

**! WARNING:** Fire Or Explosion Hazard. Do Not Pick Up Flammable Materials Or Reactive Metals.

- Go slow on inclines and slippery surfaces. Do not operate the machine on inclines that exceed 5% (3°).
- Do not keep the machine in the same position with pad / brush spinning, keep the machine moving to prevent damage to floor finish.
- If the squeegee assembly leaves streaks on the floor, raise the squeegee off the floor and wipe the blades down with a damp cloth. Pre-sweep the area to prevent leaving streaks on the floor.
- Pour a recommended defoamer into the recovery tank if excessive foam appears.

**! WARNING:** Do not allow foam to enter the float shut-off screen, vacuum motor damage will result. Foam will not activate the float shut-off screen.

- Occasionally check the Battery meter, the indicator displays the level of the batteries. When meter is in the red, stop scrubbing and recharge the batteries.

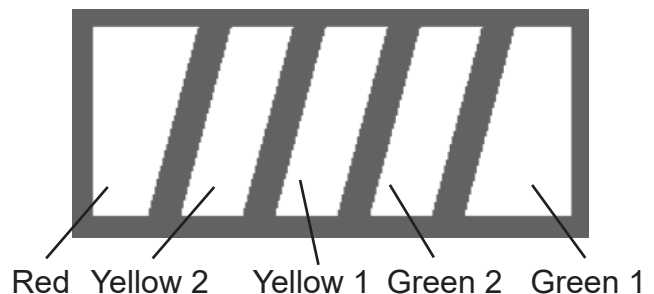

All green lights on: 100% level.

Yellow lights on, green lights off : 50% level.

Red light on, other lights off: 20% level, the machine should be stopped and the batteries should be recharged.

Red light flash: the batteries have already been discharged deeply.

- When the solution tank runs empty, turn off the Brush motor switch and lift the brush head. Keep the squeegee down and continue to vacuum until all the dirty water is picked up.

**NOTE:** See **TANK DRAINING** section to learn how to drain recovery and solution tanks.

## TANK DRAINING

- Turn off the machine.
- With the squeegee and scrub head in their “up” position, transport machine to approved area for draining tank(s).

### DRAINING THE RECOVERY TANK

Any time scrubbing is completed, or when refilling solution tank, the recovery tank should be drained and cleaned.

 **WARNING:** If the recovery tank is not drained when the solution tank has been refilled, foam or water may enter the float shut-off screen and cause damage to the vacuum motor.

- While holding the drain hose (see machine components, p5 item #10) upward, remove the cap and lower hose to drain.
- Open the recovery tank cover and rinse out the tank. Use a rag to remove any excess dirt. Clean the float shut-off screen and debris tray located in the recovery tank .

### DRAINING THE SOLUTION TANK

Any time scrubbing operation is completed, the solution tank should be drained and cleaned.

- Pull the solution clear tube(see machine components, p5 item #22) off the hose fitting, this will allow the solution to flow freely into a bucket or floor drain.
- Remove the cover of the filter assembly to drain the solution tank, check the filter screen and clean up it if necessary.
- Rinse the solution tank with clean water after every use. This will help prevent chemical buildup and clogging of the solution lines.
- After rinsing out the tank, securely reconnect the tank level hose to the hose fitting, replace the filter assembly cover and be sure the filter screen and the “O” ring is in the correct position.

## BATTERY CHARGING

 **WARNING:** Fire Or Explosion Hazard. Batteries Emit Hydrogen Gas. Keep Sparks and Open Flame Away. Keep Battery Compartment Propped Open When Charging.

- Transport the machine to a well ventilated area.
- Turn the machine off.
- If charging wet, lead acid, batteries check the fluid level before charging.
- Connect the charger’s AC power supply cord to a properly grounded receptacle.
- The charger will automatically begin to charge, you can watch the charging status on the window (machine components, p5 item #20), once the charging cycle begins, the indicator lights will progress from red, yellow to green. When the green indicator light comes on, the charging cycle is done. Unplug the charger cord.

**NOTE:** The machine will not operate when charging.



## PREVENTATIVE MAINTENANCE

 **WARNING:** Before performing any maintenance on the machine, be sure that the power is turned off, or the batteries are disconnected!

 **WARNING:** Repairs are to be completed by Authorized service centers only. Any repairs completed by unauthorized persons will void the warranty.

### DAILY MAINTENANCE

1. Remove pad driver/ brush and clean with approved cleaner.
2. Drain recovery and solution tanks completely and rinse out with clean water. Visually check the recovery tank for debris and clean out as necessary.
3. Raise the squeegee assembly off floor and wipe it down with a damp towel. Be sure to store the squeegee in the up position.
4. Remove the float shut-off assembly and rinse it out with clean water.
5. Clean machine with an approved cleaner and a damp towel.
6. Recharge the batteries.
7. Check the condition of the squeegee blade wiping edge, rotate blade if worn.

### MONTHLY MAINTENANCE

1. Clean the battery tops to prevent corrosion.
2. Check for loose battery cable connections.
3. Inspect and clean the recovery tank cover seal. Replace it if damaged.
4. Lubricate all grease points and pivot points with silicon spray and approved grease.
5. Check the machine for loose nuts and bolts.
6. Check the machine for leaks.

### MOTOR MAINTENANCE

1. Contact your dealer for any motor maintenance.
2. Motor should have the brushes checked every 250 hours. Brushes should be replaced when they are worn to a length of 10 mm or less.

### BATTERY MAINTENANCE

 **WARNING:** Batteries emit hydrogen gas. An explosion or fire can result. Keep sparks and fire away from batteries at all times.

 **WARNING:** Whenever servicing batteries, be sure to wear protective gloves. Avoid contact with battery acid at all times.

**NOTE:** For the best machine performance, keep batteries properly charged at all times. Do not let them sit in a discharged condition.

1. Always follow the battery charging directions as outlined in the BATTERY CHARGING section of this manual.
2. Keep battery tops and terminals free from corrosion. A strong solution of baking soda and water is the best way to keep the batteries corrosion free. **DO NOT ALLOW THE BAKING SODA / WATER SOLUTION TO ENTER THE BATTERY CELLS.**
3. Use a wire brush with the baking soda solution to properly clean the battery posts and connections.
4. Check battery connections for wear and loose terminals. Replace if necessary.

### MACHINE STORAGE

1. Always store the machine indoors.
2. Always store the machine in a dry area.
3. Always store the machine in its upright position.
4. Always store the machine with the pad driver/ brush raised off the floor.
5. Always store the machine with the squeegee assembly raised off the floor.
6. If storing in an area which may reach freezing temperatures, be sure to drain all fluids from the machine prior to storage. Any damage caused by freezing temperatures will not be covered by the warranty.
7. Drain the recovery tank.
8. Drain the solution tank of all fluid.

## BASIC TROUBLESHOOTING

PROBLEM	CAUSE	SOLUTION
Machine will not operate	Batteries need to be charged	Charge batteries
	Bad battery(s)	Replace battery(s)
	Loose battery cable	Tighten loose cable
Brush motor will not operate	Control handle trigger not pulled	Pull control handle trigger
	Tripped brush motor blown fuses	Replace fuse
	Bad brush motor switch	Replace brush motor switch
	Faulty brush motor or wiring	Contact ICE service Dealer
	Worn motor carbon brushes	Contact ICE service Dealer
Vacuum motor will not operate	Bad vacuum motor switch	Replace vacuum motor switch
	Bad vacuum motor relay	Replace vacuum motor relay
	Faulty vacuum motor or wiring	Contact ICE service Dealer
	Worn Motor carbon brushes	Contact ICE service Dealer
Little or no solution flow	Ball valve is shut off	Turn on the ball valve
	Clogged solution tank filter or solution hose	Clean solution tank filter or flush out solution hose
	Clogged solution Solenoid valve	Remove valve and clean
Poor water pick up	Recovery tank is full	Drain recovery tank
	Loose drain hose cap	Tighten cap
	Clogged float shut-off screen located in recovery tank	Clean screen
	Clogged squeegee assembly	Clean squeegee assembly
	Worn squeegee blades	Replace or rotate squeegee blades
	Incorrect squeegee blade deflection	Adjust squeegee blade height
	Loose vacuum hose connections	Secure hose connections
	Clogged vacuum hose	Remove clogged debris
	Damaged vacuum hose	Replace vacuum hose
	Recovery tank lid not in place	Properly position cover
	Damaged recovery tank cover seal	Replace seal
	Faulty vacuum motor	Contact ICE service Dealer
	Low battery charge	Recharge batteries
Short run time	Low battery charge	Fully recharge batteries
	Defective batteries	Replace batteries
	Batteries need maintenance	See BATTERY MAINTENANCE
	Faulty battery charger	Repair or replace battery charger

**TECHNICAL SPECIFICATIONS**

<b>MODEL</b>	<b>i15B Brush Assist</b>
<b>DIMENSIONS L</b>	31in / 790 mm
<b>DIMENSIONS W</b>	18.5 in / 468 mm
<b>DIMENSIONS H</b>	27 in / 690 mm
<b>WEIGHT</b>	93.7 lbs / 42.5Kg
<b>WEIGHT WITH BATTERIES</b>	140 lbs /63.5 Kg
<b>RECOVERY TANK CAPACITY</b>	5Gal / 19 L
<b>SOLUTION TANK CAPACITY</b>	4Gal / 15 L
<b>SQUEEGEE WIDTH</b>	18 in / 450 mm
<b>CLEANING PATH WIDTH</b>	15 in / 381 mm (Disk)
<b>PRODUCTIVITY RATE</b>	13993 ft <sup>2</sup> /1300 m <sup>2</sup> h
<b>DRIVE SYSTEM</b>	Brush Assisted
<b>BRUSH MOTOR</b>	0.27hp / 0.2KW 140 RPM
<b>VACUUM MOTOR</b>	0.54hp / 0.4KW
<b>WATER LIFT - AIR FLOW</b>	45 in / 1,143 mm
<b>BATTERIES</b>	2-12, 33Ah @ 20 hr
<b>RUN TIME PER CHARGE</b>	1.2 Hours
<b>VOLTAGE DC</b>	24V
<b>DECIBEL RATE AT OPERATOR'S EAR, INDOORS</b>	78dB(A)
<b>GRADE LEVEL, MAX</b>	5% (3°)

RECOVERY TANK GROUP

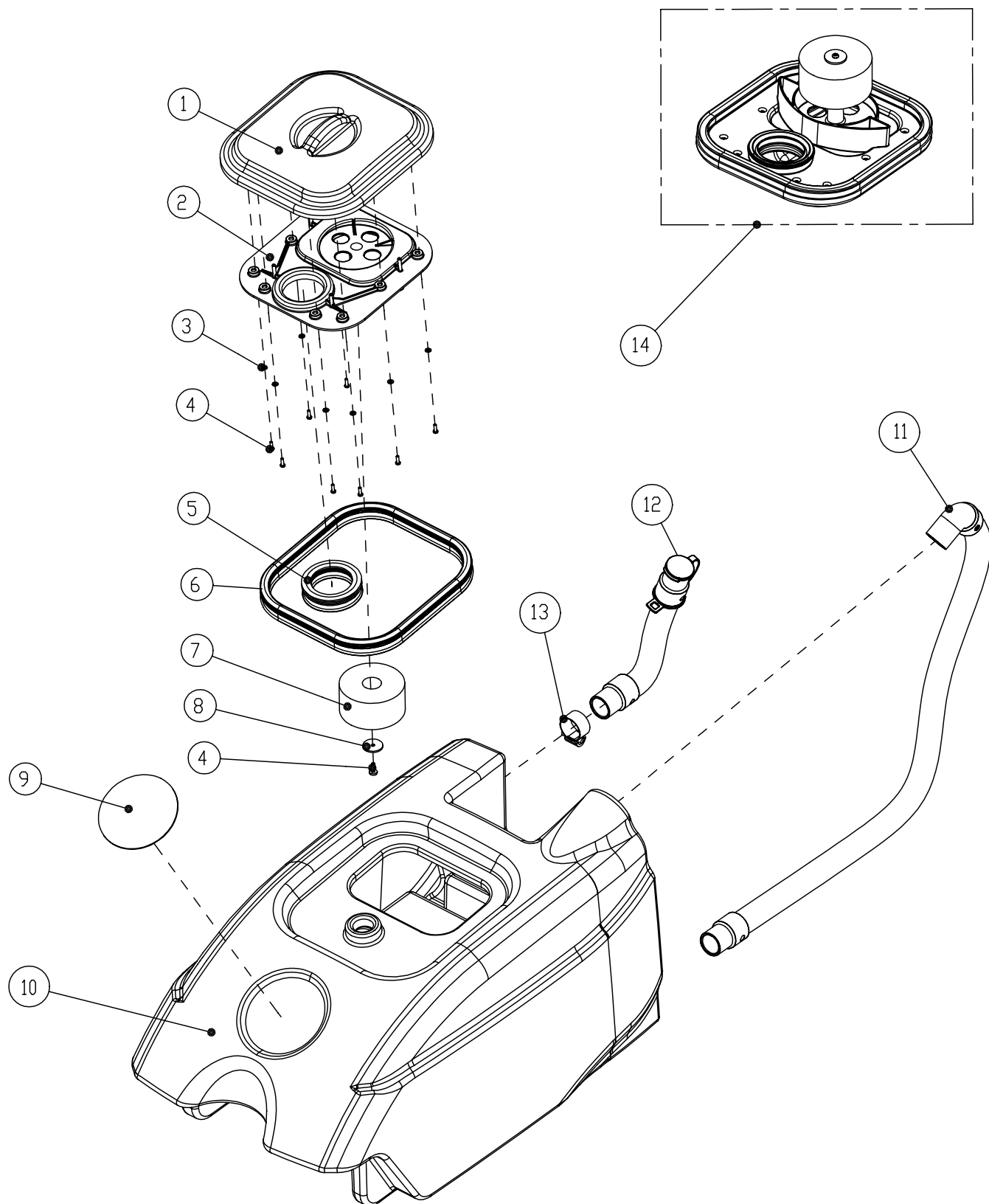

**RECOVERY TANK GROUP**

<b>DIA NO.</b>	<b>PART NUMBER</b>	<b>DESCRIPTION</b>	<b>SERIAL NUMBER</b>	<b>NO. REQ'D</b>
1	8401204	RECOVERY LID		1
2	8401205	LOWER LID OF RECOVERY TANK		1
3	1421409	FLAT WASHER M4× $\phi$ 9×0.8		8
4	1321110	SCREW,ST3.5×10		9
5	8401207	RECOVERY TANK COVER SEAL	60037100101— 60037100460	1
	8401217	RECOVERY TANK COVER SEAL	60037100461—	1
6	8401206	RECOVERY TANK COVER SEAL		1
7	8401208	FLOAT		1
8	1421425	FLAT WASHER, $\phi$ 4.3× $\phi$ 25×1.5		1
9	4010316	ICE LOGO		1
10	8401201	RECOVERY TANK		1
11	8401210	VACUUM HOSE		1
12	8401211	DRAIN HOSE		1
13	1962032	CLAMP	60037100101— 60037100460	1
	1962033	CLAMP	60037100461—	1
14	8401215	RECOVERY TANK COVER GROUP		1

## NOTES:

1. DIA NO. 5, 8401207 and 8401217, the installation and use mode are fully compatible, Follow-up maintenance unified use 8401217;
2. DIA NO. 13, 1962033 is optimized material, Follow-up maintenance unified use 1962033

**SOLUTION TANK GROUP**

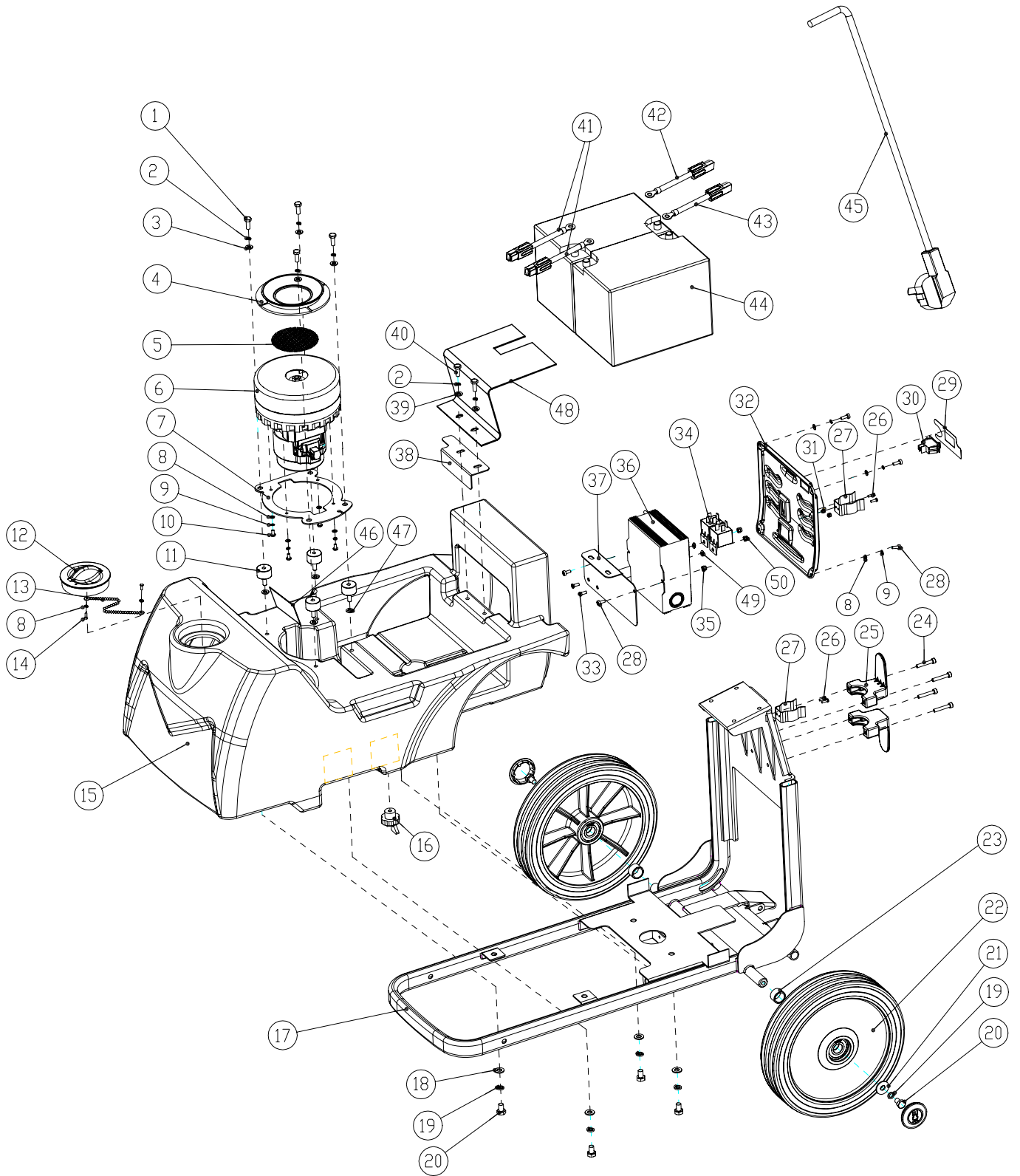

**SOLUTION TANK GROUP**

DIA NO.	PART NUMBER	DESCRIPTION	SERIAL NUMBER	NO. REQ'D
1	1221612	SCREW,M6×12		4
2	1422616	LOCK WASHER, M6		6
3	1421616	FLAT WASHER M6× $\phi$ 16×1		4
4	8401212	VACUUM SEAL		1
5	8401213	FILTER		1
6	8401203	VACUUM MOTOR,24VDC		1
7	8401209	MOUNTING PLATE		1
8	1421409	FLAT WASHER M4× $\phi$ 9×0.8		8
9	1422411	LOCK WASHER, M4		8
10	1321213	SCREW,ST4×13		4
11	8310208	ISOLATER, M6	60037100101—60037100203	4
	8401145	ISOLATER, M6	60037100204—	4
12	8401202	FRONT FILL COVER		1
13	8050153	CHAIN,FRONT COVER		1
14	1321110	SCREW,ST3.5×10		2
15	8401101	SOLUTION TANK		1
16	8401121	SOLUTION DRAIN CAP		1
17	8401102	MAIN FRAME		1
18	1421824	FLAT WASHER M8× $\phi$ 24×2		4
19	1422821	LOCK WASHER, M8		6
20	1021820	SCREW,M8×20		6
21	1421828	FLAT WASHER M8× $\phi$ 28×3		2
22	8401108	WHEEL,10 INCH		2
23	8401127	BUSHING		2
24	1511525	SCREW,M5×25,HEX SOCKET		4
25	4010405	CORD WRAP		2
26	1221310GL	SCREW,M3×10,HEX HEAD		4
27	8401131	HOSE CLAMP		2
28	1221410	SCREW,M4×10		6
29	8401133	DECAL,SWITCH		1
30	6210503	ROCKER SWITCH		1
31	1123305	NUT,LOCK M3		2
32	8401104	REAR COVER		1
33	1222512	SCREW,M5×12		2

# PARTS LIST

## SOLUTION TANK GROUP

DIA NO.	PART NUMBER	DESCRIPTION	SERIAL NUMBER	NO. REQ'D
34	8114707	RELAY 40A		2
35	1123406	NUT,LOCK M4		2
36	8401107	BATTERY CHARGER,24V,SPE	60037100101—60037100723	1
	8401109	BATTERY CHARGER,24V,QQE	60037100724—	1
37	8401103	MOUNTING PLATE		1
38	8401132	MOUNTING PLATE		1
39	1421612	LOCK WASHER, M6		2
40	1021616	SCREW M6×16		2
41	8401711	BATTERY CONNECT CABLE,RED		2
42	8401712	BATTERY CONNECT CABLE,BLACK		1
43	8401713	BATTERY CONNECT CABLE,RED		1
44	8401710	BATTERY (LEOCH AGMU1 (12V 35AH))		2
45	8112030	CHARGER CORD (FOR US)		1
46	8401906	INDICATED LABEL	60037100514—	1
47	1421618	FLAT WASHER M6× $\phi$ 18×1.6	60037100204—	4
48	8401147	SHIELDED PIECE	60037100514—	1
49	1421510	FLAT WASHER M5× $\phi$ 10×1.0		2
50	1123507	NUT M5		2

NOTES:

1. DIA NO. 11, 8401145 is optimized material. Follow-up maintenance unified use 8401145.

2. DIA NO. 47, 1421618 FLAT WASHER, which is matching with 8401145 (DIA NO. 11).

3. DIA NO. 36, 8401107 and 8401109, they are different in the power interface position size.

So, the aftermarket component of the 8401107 is "8401109 1pc+8401103 1pc", and the aftermarket component of the 8401109 is still "8401109 1pc".



**HANDLE ASSEMBLY**

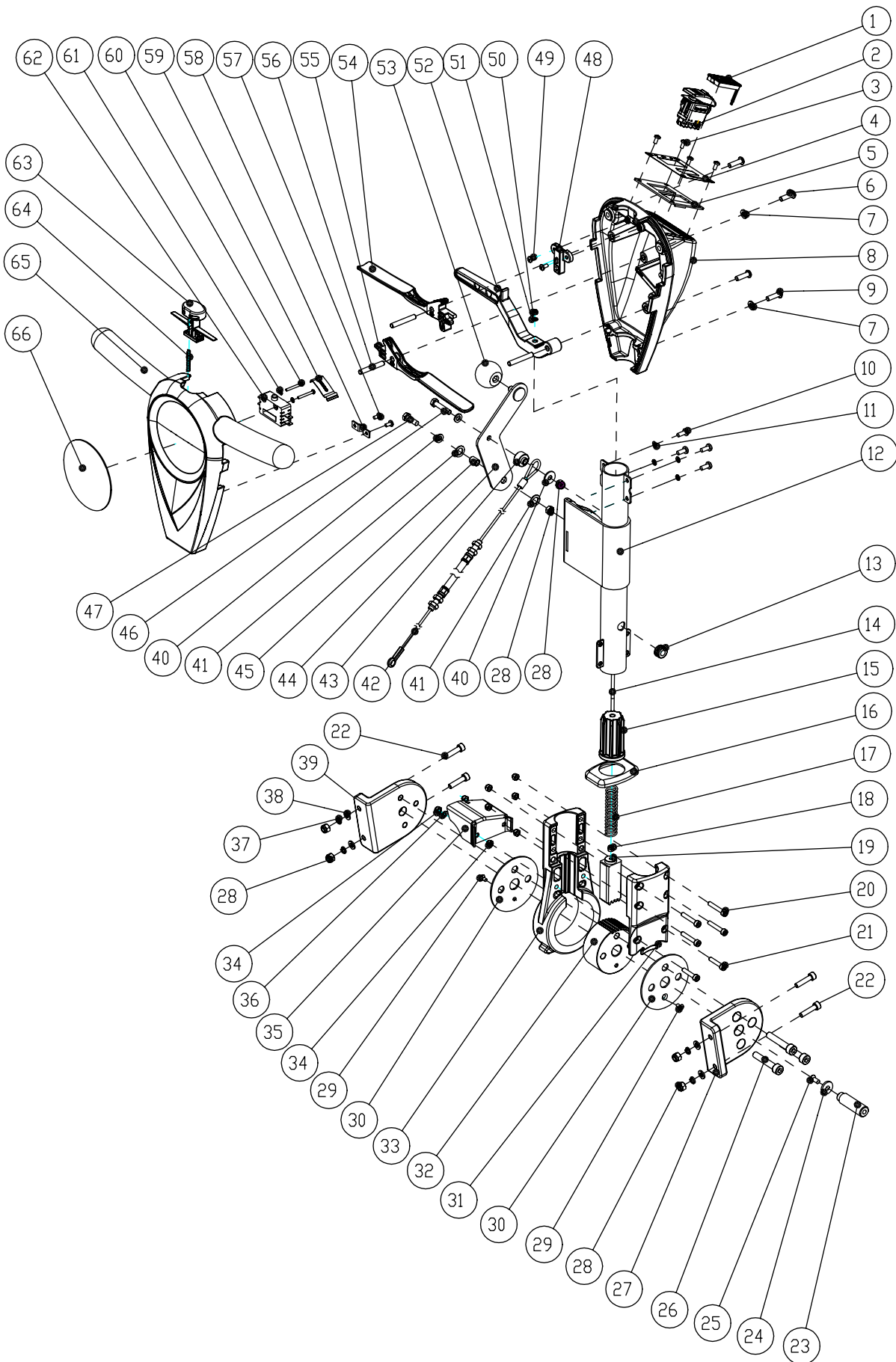

## PARTS LIST

### HANDLE ASSEMBLY

DIA NO.	PART NUMBER	DESCRIPTION	SERIAL NUMBER	NO. REQ'D
1	8014063	BATTERY CAPACITY METER		1
2	1885301	POWER CONTROL SWITCH		1
3	1211410	SCREW, M4×10		4
4	8401704	DECAL, CONTROL PANEL		1
5	8401703	CONTROL PANEL		1
6	1512625	SCREW, M6×25		2
7	1421616	FLAT WASHER M6× $\phi$ 16×1.0		4
8	8401401	THE HANDLE BACK COVER		1
9	1512635	SCREW, M6×35		2
10	1211512	SCREW, M5×12		4
11	1434500	TOOTH WASHER, $\phi$ 5		4
12	8401402	HANDLE TUBE		1
13	8401405	CONTROL LINE PROTECTION RING		1
14	8401403	PULL ROD		1
15	4010207	SEAT, SPRING		1
16	4010216	SEAL, SEAT		1
17	4010208	SPRING, LEVELING		1
18	1111403	NUT M4		1
19	4010211	INSERT		1
20	1511530	SCREW, M5×30		4
21	1511540	SCREW, M5×40		2
22	1521620	SCREW, M6×20		4
23	4010110	SHAFT		1
24	4010114	WASHER		1
25	1222512	SCREW, M5×12		1
26	1521845	SCREW, M8×45		3
27	5012416	HANDLE, STAND, LEFT		1
28	1123608	NUT M6		4
29	1212410	SCREW, M4×10		2
30	4010212	COVER		2
31	4010202	COVER, SEAT GEAR		1
32	8401404	GEAR		1
33	4010201	MOUNTING BASE, GEAR		1
34	1123507	NUT M5		8
35	8401415	MOUNTING BRACKET		1
36	1421510	FLAT WASHER M5× $\phi$ 10×1.0		2
37	1422616	LOCK WASHER, M6		4
38	1421612	FLAT WASHER M6× $\phi$ 12×1.0		4
39	5012415	HANDLE, STAND, RIGHT		1
40	1421618	FLAT WASHER M6× $\phi$ 18×1.6		3
41	8113111	NYLON FLAT WASHER $\phi$ 12.9× $\phi$ 25.4×0.8		2

**HANDLE ASSEMBLY**

<b>DIA NO.</b>	<b>PART NUMBER</b>	<b>DESCRIPTION</b>	<b>SERIAL NUMBER</b>	<b>NO. REQ'D</b>
42	8401411	SQUEEGEE LIFT CABLE		1
43	8014101	LIFTING CABLE SPACER		1
44	8401407	HANDLE,SQUEEGEE LIFT		1
45	8401413	AXLE SLEEVE		1
46	1021630	HEX HEAD BOLT M6×30,SS		1
47	1021620	HEX HEAD BOLT M6×20,SS		1
48	4010317	SEAT,BALL		1
49	1211408	SCREW, M4×8		2
50	1123406	NUT M4		1
51	1421412	FLAT WASHER M4× $\phi$ 12×1.0		1
52	4010304	LEVELONG ROD		1
53	8113104	BALL KNOB M8		1
54	4010330	TRIGGER,SWITCH,RIGHT		1
55	4010331	TRIGGER,SWITCH,LEFT		1
56	4010314	PIN		4
57	1221406	SCREW M4×6		2
58	4010311	CLAMP,CORD		1
59	4010323	SPRING,SWITCH		1
60	1211325	SCREW M3×25		2
61	1434300	TOOTH WASHER M3		2
62	4010308	SWITCH		1
63	4010307	SAFETY,BUTTON		1
64	4010333	SPRING,SAFTY		1
65	8401408	FRONT COVER		1
66	4010316	ICE,LOGO		1

**SCRUB HEAD GROUP**

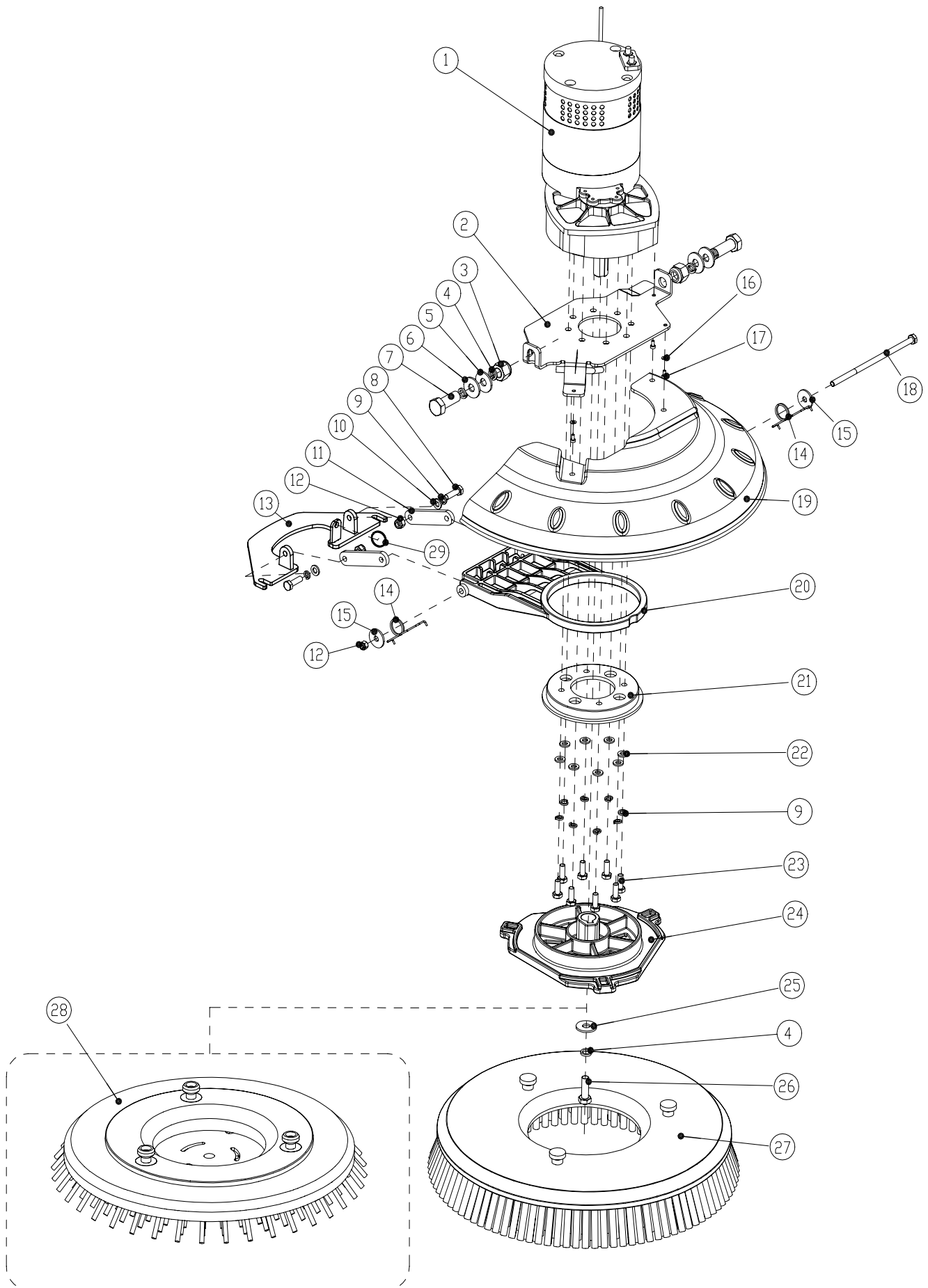

**SCRUB HEAD GROUP**

<b>DIA NO.</b>	<b>PART NUMBER</b>	<b>DESCRIPTION</b>	<b>SERIAL NUMBER</b>	<b>NO. REQ'D</b>
1	8401310	BRUSH MOTOR,24VDC,KIT		1
2	8401303	MOUNTING PLATE		1
3	1123810	LOCK NUT M8		2
4	1422821	WASHER LOCK $\phi 8$		5
5	1421824	FLAT WASHER M8 $\times\phi 24\times 2.0$		2
6	1421816	FLAT WASHER M8 $\times\phi 16\times 1.0$		2
7	1021835	SCREW M8 $\times 35$		2
8	1021620	SCREW M6 $\times 20$		2
9	1422616	WASHER LOCK $\phi 6$		10
10	1421616	FLAT WASHER M6 $\times\phi 16\times 1.0$		2
11	8401512	CONNECTING ROD		2
12	1123608	LOCK NUT M6		3
13	8401511	SQUEEGEE MOUNT BRACKET		1
14	8401515	SPRING		2
15	1421622	FLAT WASHER M6 $\times\phi 22\times 2.0$		2
16	1421409	FLAT WASHER M4 $\times\phi 9\times 1.0$		3
17	1221410	SCREW M4 $\times 10$		3
18	8401516	SCREW		1
19	8401301	BRUSH PLATE COVER		1
20	8401513	BRACKET,BRUSH MOTOR		1
21	8401514	MOUNT,BRUSH MOTOR		1
22	1421612	FLAT WASHER M6 $\times\phi 12\times 1.0$		8
23	1021616	SCREW M6 $\times 16$		8
24	8401305	BRUSH PLATE HOLDER		1
25	1421828	FLAT WASHER M8 $\times\phi 28\times 2.0$		1
26	1021825	SCREW M8 $\times 25$		1
27	9050015	15"BRUSH		1
27-1	9050015P	15"BRUSH (SOFT WHITE) (OPTION)		1
28	9040015	15"PAD DRIVER		1
29	8401520	SQUEEGEE CABLE RING		1

**SQUEEGEE GROUP**

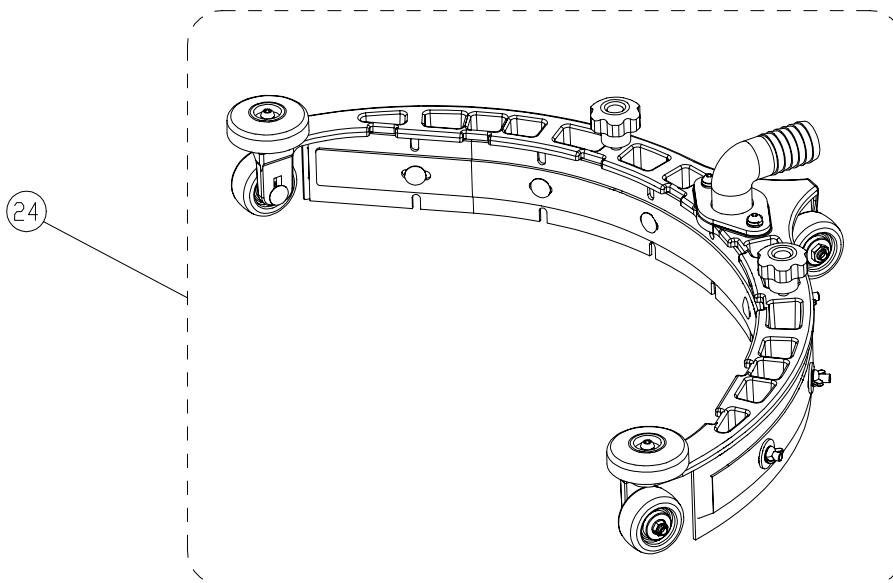
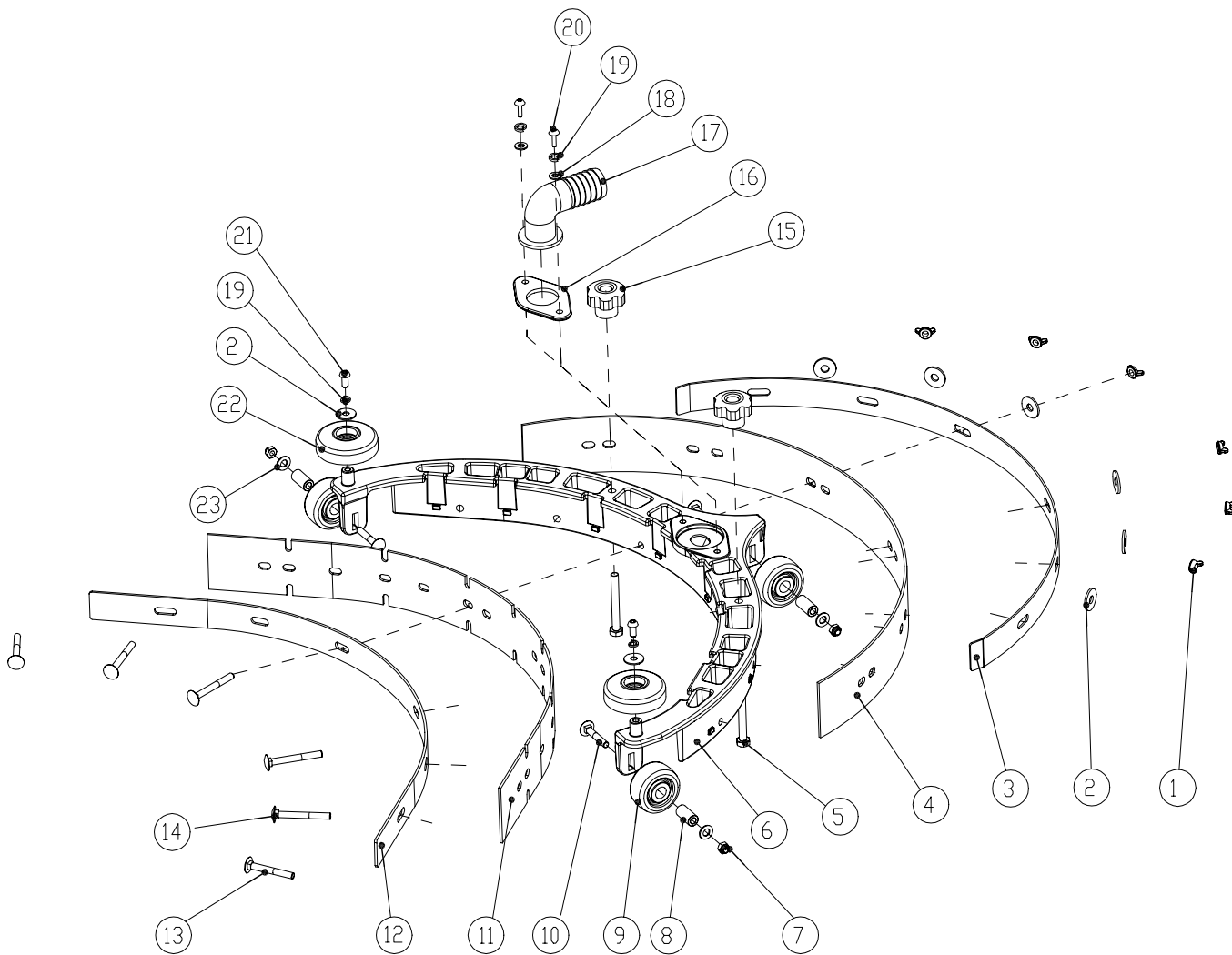

**SQUEEGEE GROUP**

DIA NO.	PART NUMBER	DESCRIPTION	SERIAL NUMBER	NO. REQ'D
1	1127510	NUT M5		6
2	1421515	FLAT WASHER M5× $\phi$ 16×1.0		8
3	8401504	CLAMP ASSEMBLY,REAR		1
4	8401503	SQUEEGEE BLADE,REAR,LINATEX		1
	8401543	SQUEEGEE BLADE,REAR,PU		1
5	1021650	HEX HEAD BOLT M6×50		2
6	8401501	SQUEEGEE HOUSING		1
7	1123507	NUT M5		3
8	8401517	AXLE SLEEVE		3
9	8401518	SQUEEGEE WHEEL,1.5INCH		3
10	1033535	SCREW M5×35		3
11	8401502	SQUEEGEE BLADE,FRONT,LINATEX		1
	8401542	SQUEEGEE BLADE,FRONT,PU		1
12	8401505	CLAMP ASSEMBLY,FRONT		1
13	1033540	SCREW M5×40		2
14	1033545	SCREW M5×45		4
15	7000177	KNOB		2
16	8401506	PLATE,COUPLING		1
17	8401507	ANGLE COUPLING		1
18	1421510	FLAT WASHER M5× $\phi$ 10×1.0		2
19	1422513	WASHER LOCK $\phi$ 5		4
20	1321316	SELF-TAPPING SCREW ST4.8×16		2
21	1321310	SELF-TAPPING SCREW ST4.8×10		2
22	8411607	BUMPER WHEEL		2
23	1421511	FLAT WASHER M5× $\phi$ 12×1.0		3
24	8401500	SQUEEGEE ASSEMBLY,LINATEX		1

## NOTES:

1. DIA NO. 4, 8401503 is standard material and 8401543 is alternative material;
2. DIA NO. 11, 8401502 is standard material and 8401542 is alternative material.

SOLUTION FLOW GROUP

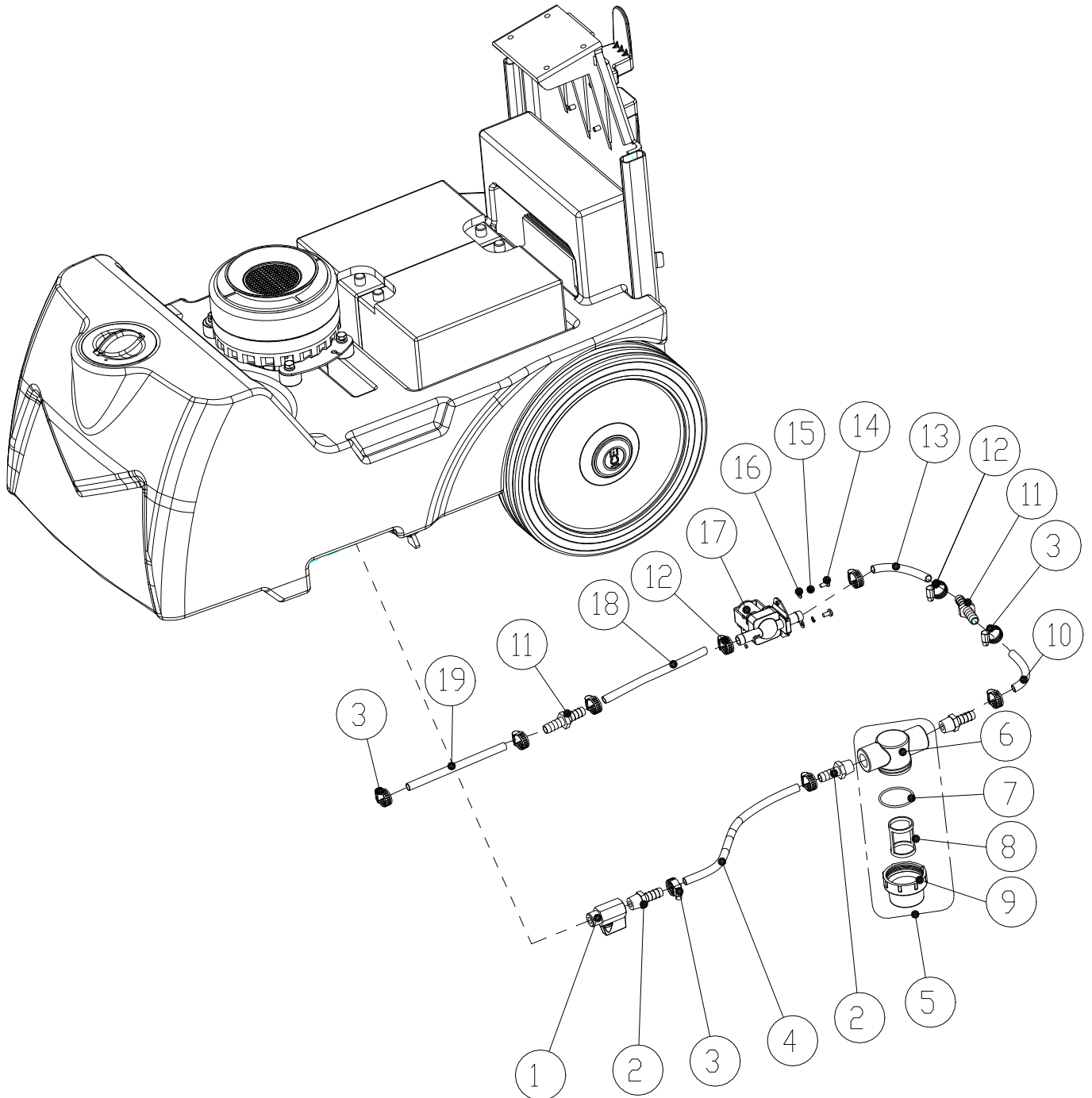



**SOLUTION FLOW GROUP**

<b>DIA NO.</b>	<b>PART NUMBER</b>	<b>DESCRIPTION</b>	<b>SERIAL NUMBER</b>	<b>NO. REQ'D</b>
1	8018006	BALL VALVE,3/8		1
2	8401116	ELBOW,3/8		3
3	8401142	CLAMP		6
4	8401134	TUBING,ID=8MM L=300mm		1
5	8401115	FILTER ASSEMBLY		1
6	8401111	BASE,FILTER ASSEMBLY		1
7	8401114	O RING		1
8	8401112	SCREEN,FILTER		1
9	8401113	CAP,FILTER ASSEMBLY		1
10	8401135	TUBING,ID=8MM L=120mm		1
11	8401129	ELBOW		2
12	1962016	CLAMP		4
13	8401136	TUBING,ID=12MM L=120mm		2
14	1221410	SCREW M4×10		2
15	1422411	WASHER LOCK $\phi$ 4		2
16	1421409	FLAT WASHER M4× $\phi$ 9×1.0		2
17	8018007	SOLENOID VALVE,24VDC		1
18	8401137	TUBING,ID=12MM L=200mm		1
19	8401138	TUBING,ID=8MM L=150mm		1

## PARTS LIST

---

### WEARABLE PARTS

<b>DIA NO.</b>	<b>PART NUMBER</b>	<b>DESCRIPTION</b>	<b>NO. REQ'D</b>
1	8401108	WHEEL, 10INCH, WITH BEARINGS	2
2	8411607	BUMPER WHEEL	2
3	8401518	SQUEEGEE WHEEL,1.5INCH	3
4	8401502	FRONT SQUEEGEE BLADE, LINATEX	1
5	8401503	REAR SQUEEGEE BLADE, LINATEX	1
6	9040015	PAD HOLDER, 15 INCH	1
7	9050015	BRUSH, 15 INCH	1

# I15B Wiring Diagram

## WIRING DIAGRAM (i15B)

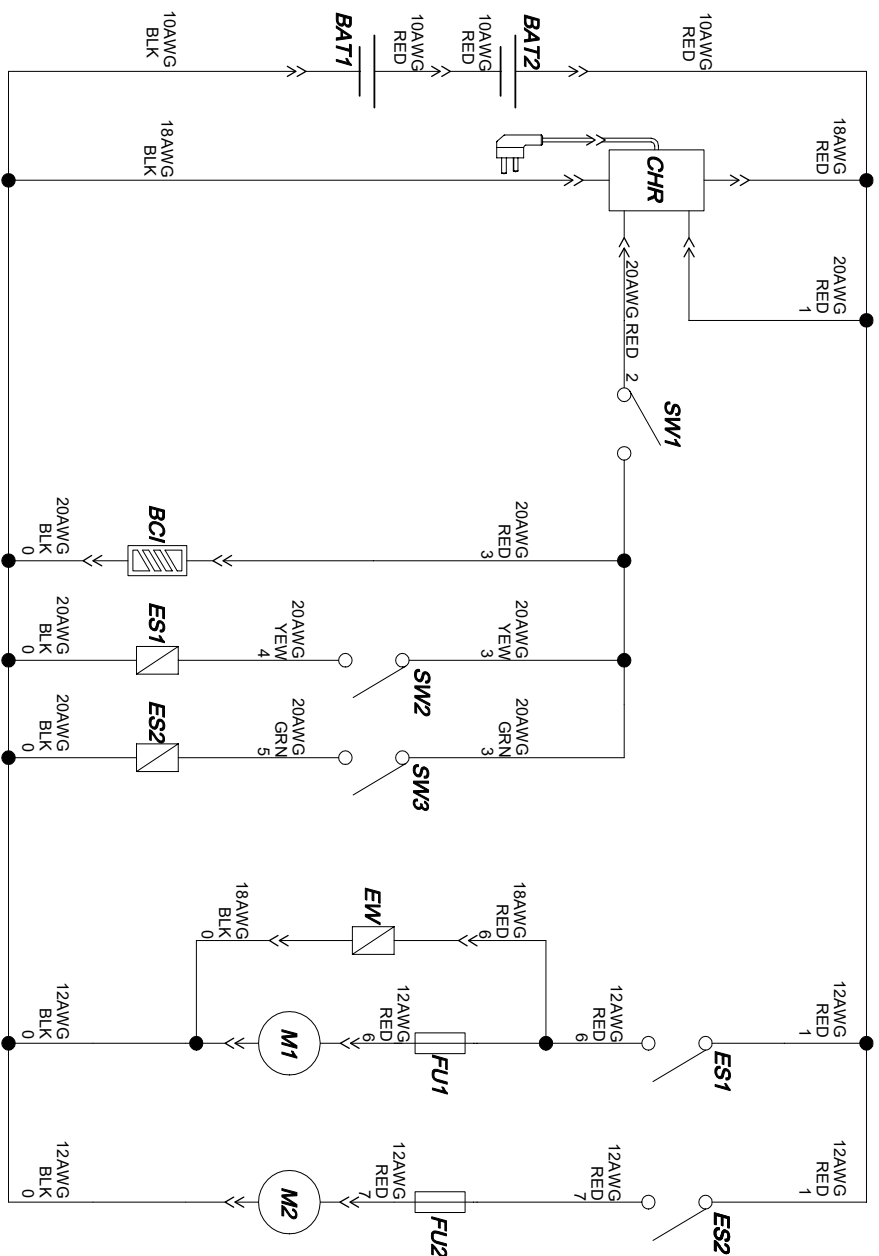

- BAT1: 12V battery
- BAT2: 12V battery
- FU1: FUSE 25A
- FU2: FUSE 30A
- CHR: Charger
- SW1: Main switch
- SW2: Brush motor switch and solution solenoid valve
- SW3: Vacuum motor switch
- BCI: Battery capacity indicator
- ES1: Brush motor switch and solution solenoid valve
- ES2: Vacuum motor relay
- EW: Solution solenoid valve
- M1: Brush motor
- M2: Vacuum motor

Red : Red  
 BLK: Black  
 GRN: Green  
 YEW: Yellow

## CERTIFICATE OF QUALIFIED

MODEL: \_\_\_\_\_  
INSPECTOR: \_\_\_\_\_

SERIAL NO: \_\_\_\_\_  
DATE: \_\_\_\_\_

ICE Cobotics (Guangdong) Co. Ltd

TEL: (+86) 769 8186 9000

FAX : (+86) 769 8186 3000